



DOOR MANAGEMENT SYSTEMS

Implementation devices for door management systems



5 devices with



5 different functions

Stop/go display
SLIM-DUALUX



Stop/go sensorized display
SLIM-DUALUX



Push-button unit
SLIM-DUALPUSH

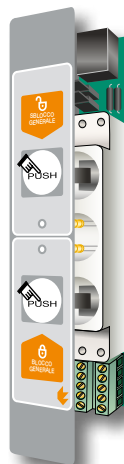

Emergency "mushroom" button
SLIM-HELPPUSH

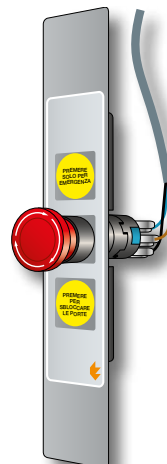

Intercom
SLIM-DUALVOX



in a unified & convertible format

NEW

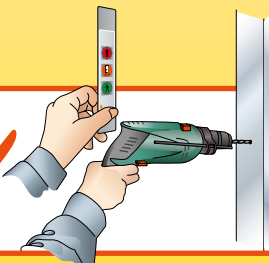

FLAT-DUALUX

ultra-slim stop/go display for easy installation

FOR AVAILABLE TYPES see pag. 80

SLIM & MODULAR

Ultra-slim and super-compact in a unified & convertible format.

Stop/go display
SLIM-DUALUX

Stop/go sensorized display
SLIM-DUALUX No-touch

Push-button unit
SLIM-DUALPUSH

Push-button with "mushroom"
SLIM-HELPPUSH

Intercom unit
SLIM-DUALVOX

Keypad
SLIM-CODEGUARD

Badge reader
SLIM-PASSGUARD

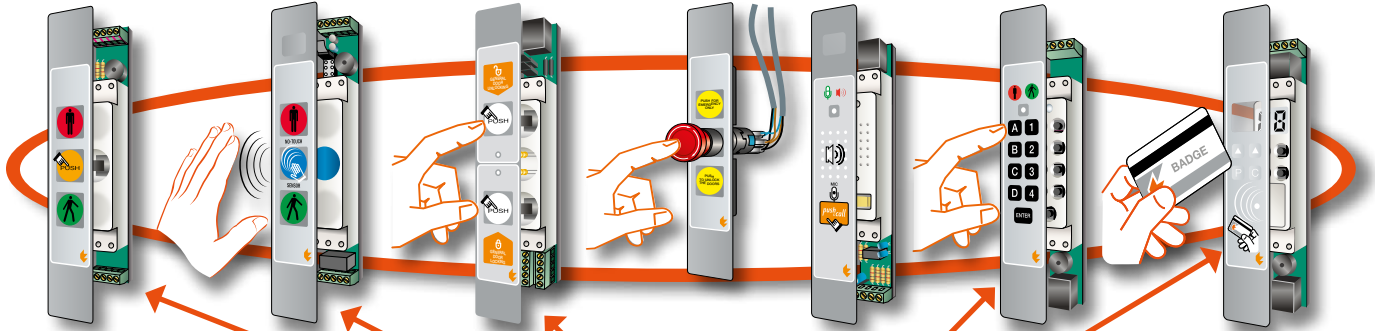

DOOR MANAGEMENT SYSTEMS

Unified module because....

A full SLIM & MODULAR range of devices with different functions, operations and purposes (stop and go displays, entryphones, keypads, such as code keypads, badge readers and micro stop and go display control units of the same series...) designed and made keeping a single module of the same size for all as a base element. In fact, all the devices have the same appearance, size and modularity to be interchangeable and housed in the same unified chasing of the previous lock.

Convertible because...

Using unified flanges, cases and boxes, any unified SLIM & MODULAR device is convertible into 5 different types that can be installed in any way, next to the door, based on the assembly needs found in the field.

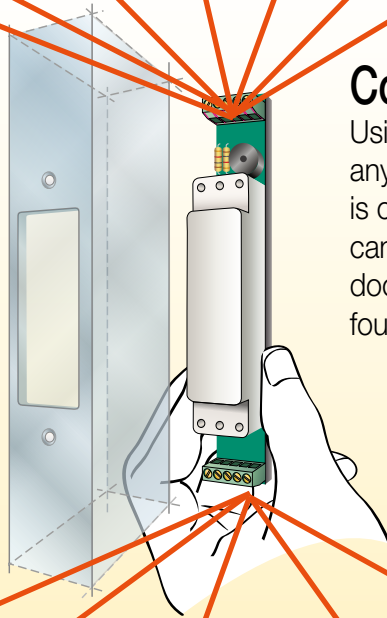

Assembly type

1

fully aligned concealed for recess-mounting without flange on the same plane of the door frame panel

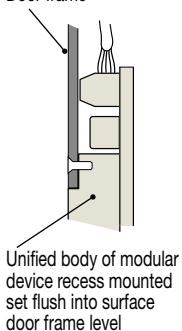

Assembly type

2

fully aligned at milling for recess-mounting with front flange on the same plane of the panel surface

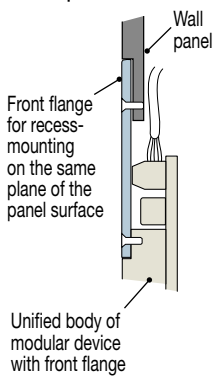

Assembly type

3

for conventional flush mounting with front flange overlapping door frame

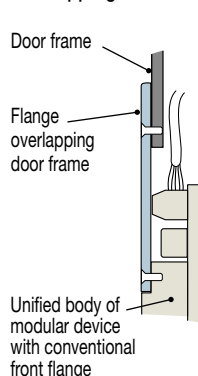

Assembly type

4

for surface mounting with using housing

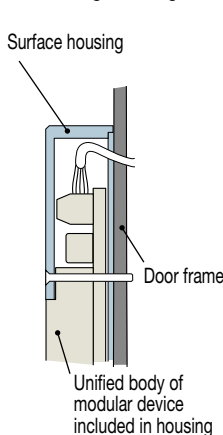



Assembly type

5

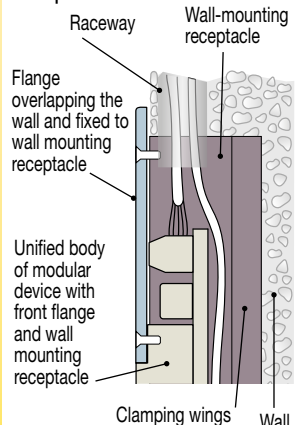
for recessed wall-mounting with flange and wall-mounting receptacle

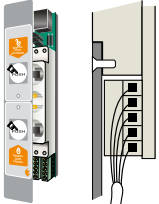
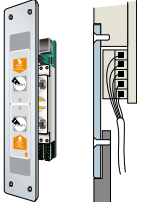
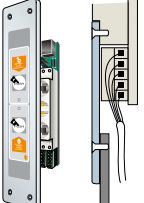
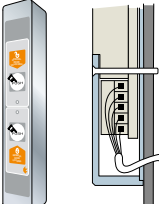
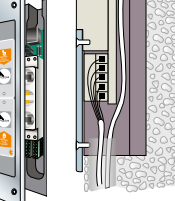

 <h2 style="text-align: center;">SLIM-DUALPUSH</h2> <h3 style="text-align: center;">PROFESSIONAL PUSH-BUTTON PANELS</h3> <p style="text-align: center;">for multiple independent controls</p>		<h3 style="text-align: center;">Export Product-list</h3> <p style="text-align: center;">January 2024</p>  <h2 style="text-align: center;">TECNODIMENSIONE®</h2>	
<p>Fitted with 2 single PUSH buttons, each of which may have the following characteristics:</p> <ul style="list-style-type: none"> • C = Pushbutton with temporary contact ("ON" when the button is held down and return to "OFF" when it is released). • I = Switch with stable ON/OFF contact ("ON" when the switch is initially pressed, "OFF" when it is pressed a second time). <p><i>NOTE = See also the codes of the applicable models.</i> Each button "A" or "B" is respectively lined to 2 output controls = 1 NO contact + 1 NC contact, both "dry" and free from voltage with a capacity of 0.5 A/12 Vdc.</p>		<ul style="list-style-type: none"> - 2 yellow LED respectively associated with the corresponding button ("A" or "B") to confirm successful activation of command". - With 2 screw-type terminal boxes, each with 5 terminals, for conventional cabling. - Jumper bridges already programmed by the factory. - 1 adhesive cover in polycarbonate, 180 x 30 mm, R2,5, thickness 0.3 mm with 7-colour international symbols; with 2 windows for the personalised indication of commands. 	
Models for 12Vdc/70mA power supply (on request on order models 24Vdc)		MODELS	Q.ty N°
<p>Assembly type 1 fully aligned concealed for recess-mounting without flange on the same plane of the door frame panel *</p> 	<p>SLIM-DUALPUSH push button panels type 1 with individual dual controls and fully aligned concealed for recess-mounting on the same plane of the door frame panel without flange. Ideal to achieve a "smooth" (without roughness) that is easy to clean. Supplied with front panel and gap G for sections with a thickness of 1.6 mm. Complete with self-adhesive cover designed to be applied after the final installation of the system.</p> <p>*In this case it is advisable to prepare the recess during the door frame machining.</p>	<p>034971CCM2U (with 2 C buttons) 034971CIM2U (with 1 C button + 1 I switch) 034971IIM2U (with 2 I switches)</p>	
	<p>Same with front panel and gap G for sections with a thickness of 3 mm. Add suffix 3 to the code of the selected model.</p>	<p>034971CCM2U3 (with 2 C buttons) 034971CIM2U3 (with 1 C button + 1 I switch) 034971IIM2U3 (with 2 I switches)</p>	
<p>Assembly type 2 fully aligned at milling for recess-mounting with front flange on the same plane of the panel surface ◆</p> 	<p>SLIM-DUALPUSH push button panels type 2 with individual dual controls for aligned recessed flush fitting in bottom of panel using front flange (e.g. To mount on wall panel next to the door frame on the post where no chasing can be carried out). Supplied with front flange in anodized aluminium with "silver" finish - 250 x 50mm, thickness 2.5 mm or recess-mounting on the same plane of the panel surface for aligned recessed flush fitting in bottom of plane using front flange. Cover pre-assembled and fixed into the flange niche.</p> <p>◆ In this case, it is advisable to prepare sunk milling during the panel machining phase.</p>	<p>034972CCM2U (with 2 C buttons) 034972CIM2U (with 1 C button + 1 I switch) 034972IIM2U (with 2 I switches)</p>	
<p>Assembly type 3 for conventional flush mounting with front flange overlapping door frame</p> 	<p>SLIM-DUALPUSH push button panels type 3 with individual dual controls. For traditional recessed fitting using flange. Supplied with front flange in anodized aluminium with "silver" finish - 250 x 50mm, thickness 4 mm for flush mounting. Cover pre-assembled and fixed into the flange niche.</p> <p>Mounting can be carried out "on site", directly onto the installed door frame.</p>	<p>034973CCM2U (with 2 C buttons) 034973CIM2U (with 1 C button + 1 I switch) 034973IIM2U (with 2 I switches)</p>	
<p>Assembly type 4 for surface mounting with using housing</p> 	<p>SLIM-DUALPUSH push button panels type 4 for mounting placed on surface using housing. With extra-strong protective housing, made in anodized silver finish aluminium (35 x 25 x 215 mm). Self-adhesive cover in polycarbonate, provided separately and designed to be used as final cover to hide the 4 fixing screws of the housing on the door frame.</p> <p>Useful when you wish to avoid recess-mounting or cuts on the door frame.</p>	<p>034974CCM2U (con 2 pulsanti C) 034974CIM2U (with 1 C button + 1 I switch) 034974IIM2U (with 2 I switches)</p>	
<p>Assembly type 5 for recessed wall-mounting with flange and wall-mounting receptacle</p> 	<p>SLIM-DUALPUSH push button panels type 5 with individual dual controls for recessed assembly using flange and wall box. Supplied with front flange in anodized aluminium with "silver" finish - 250 x 50mm, thickness 4 mm, to be fixed to the housing by placing on wall surface. Self-adhesive cover in polycarbonate pre-assembled and fixed into the flange niche. Also fitted with wall box with "wings" for rapid anchoring (65 x 30 x 230 mm), in plastic taken from single block to be assembled "in a niche" in the wall to house the body of the push button panel.</p> <p>Wall niche and cable channel to be prepared beforehand.</p>	<p>034975CCM2U (with 2 C buttons) 034975CIM2U (with 1 C button + 1 I switch) 034975IIM2U (with 2 I switches)</p>	

Special configurations available at extra charge: Cover with your logo and/or customized.

For sizes, measurements and details of chasing, application examples and connection diagrams, see page 71.

SLIM-DUALPUSH PUSH-BUTTON PANELS - sizes, application examples and connection diagram

Assembly type 1 total alignment, lock recessed into surface without flange

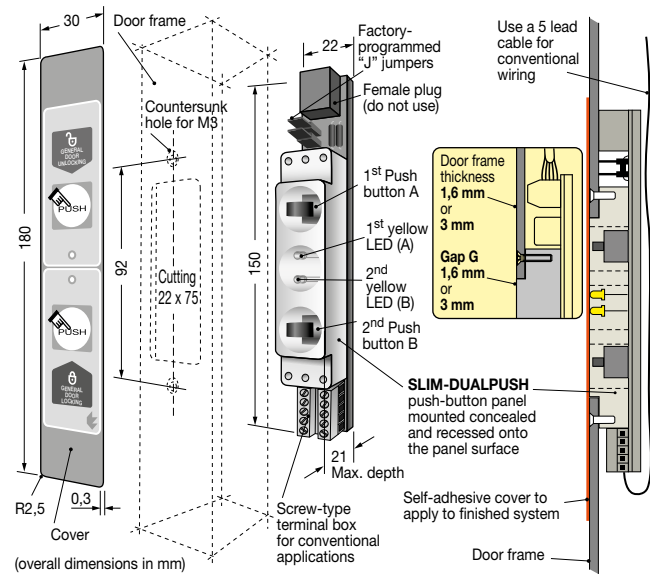

Assembly type 2 alignment at bottom with front flange "flush with surface" at bottom

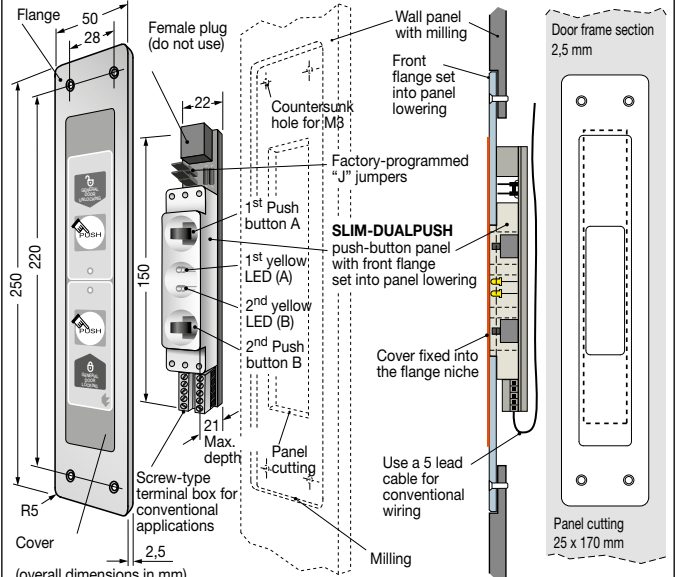

Assembly type 3 traditional fitting with front flange over the lock

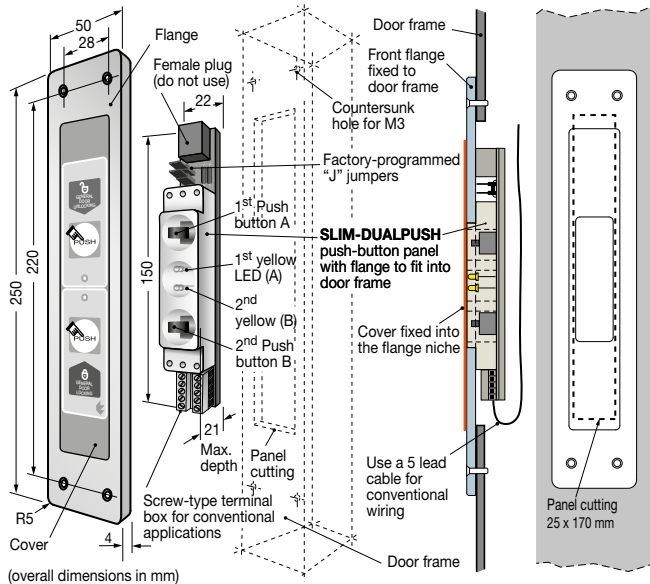

Assembly type 4 for mounting placed on surface using housing

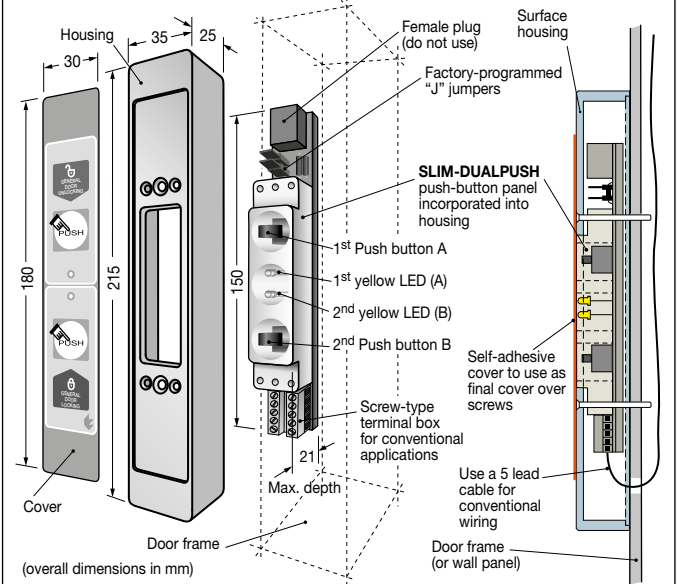

Assembly type 5 for recessed wall mounting with flange and wall box

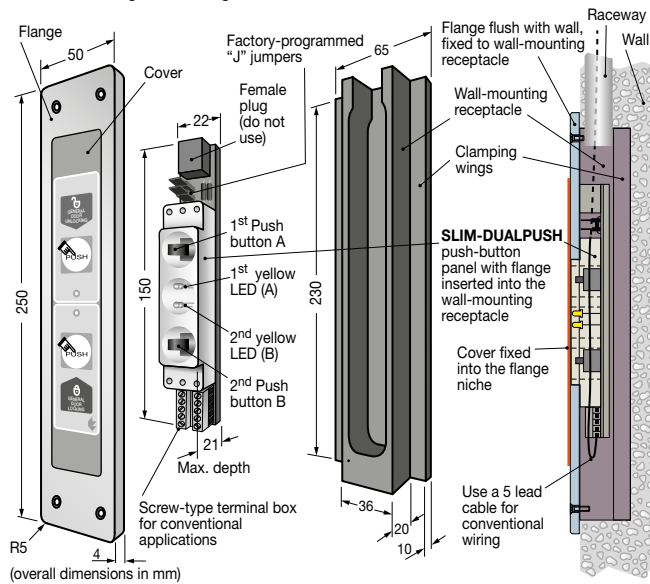

CONNECTION DIAGRAM valid for all 5 types

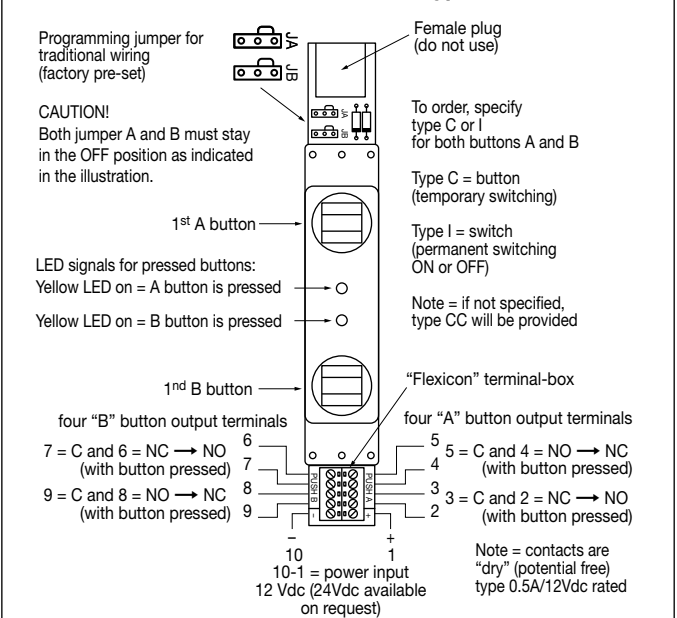

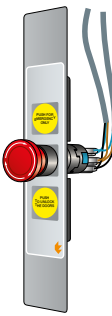
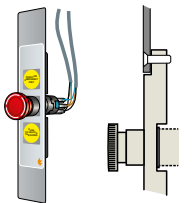
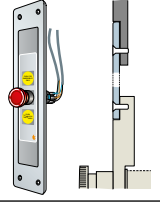
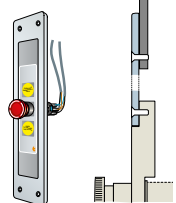
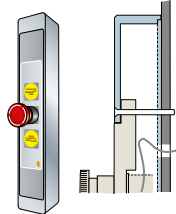
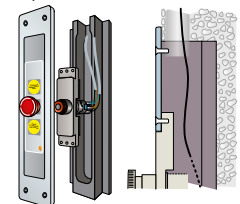
<h2 style="color: orange;">SLIM-HELPPUSH</h2> <h3>PROFESSIONAL PUSH-BUTTON PANELS</h3> <p>with emergency mushroom head button</p>		Export Product-list January 2024  TECNODIMENSIONE®		
	<ul style="list-style-type: none"> - With flying cables 2 metres long, precabled in the factory, each with 3 conventional cabling terminals for any type of system. - Fitted with a red "mushroom" head button for manual emergency operations (for example to open part and/or all the doors, stop the operating cycle, send a fire alarm, etc.). Monostable ON/OFF "mushroom" head button (when pressed, it remains permanently ON). The button can be reset (OFF) with a specific voluntary action by turning the red head of the button clockwise. 		<ul style="list-style-type: none"> - 2 SPDT independent exchange output contacts - "dry" type with 1A/12-24 Vdc capacity; the 1st contact (flying cable A) is the emergency door release control. The 2nd contact (flying cable B) can be used for additional local and/or remote optical/acoustic signals (alarms, special controls, etc.). - 1 adhesive cover in polycarbonate, 180 x 30 mm, R2,5, thickness 0.3 mm with 7-colour international symbols; with 2 windows for the personalised indication of commands. 	
	Models for 12 Vdc/70mA power supply and/or 24Vdc		Ordering information	Q.ty
		MODELS	N°	
Assembly type 1 fully aligned concealed for recess-mounting without flange on the same plane of the door frame panel * 	SLIM-HELPPUSH push button panel type 1 with "mushroom" pressure button with fully aligned concealed for recess-mounting on the same plane of the door frame panel without flange. Concealed flush mounting in door frame (only red head of mushroom sticks out). Ideal to achieve a surface that is easy to clean. Supplied with front panel and gap G for sections with a thickness of 1.6 mm. Complete with self-adhesive cover designed to be applied after the final installation of the system. * In this case it is advisable to prepare the recess during the door frame machining.		034971E0M2U	
	Same with front panel and gap G for sections with a thickness of 3 mm.		034971E0M2U3	
Assembly type 2 fully aligned at milling for recess-mounting with front flange on the same plane of the panel surface ♦ 	SLIM-HELPPUSH push-button panel type 2 with "mushroom" pressure button for aligned recessed flush fitting in bottom of panel using front flange (only red head of mushroom sticks out) (e.g. To mount on wall panel next to the door frame on the post where no chasing can be carried out). Supplied with front flange in anodised aluminium with "silver" finish, 250 x 50 mm, thickness 2.5 mm for recess-mounting on the same plane of the panel surface for aligned recessed flush fitting in bottom of plane using front flange. Cover pre-assembled and fixed into the flange niche. ♦ In this case, it is advisable to prepare sunk milling during the panel machining phase.		034972E0M2U	
Assembly type 3 for conventional flush mounting with front flange overlapping door frame 	SLIM-HELPPUSH push-button panel type 3 with "mushroom" pressure button for traditional recessed fitting using flange. Supplied with front flange in anodized aluminium with "silver" finish - 250 x 50mm, thickness 4 mm for flush mounting. Cover pre-assembled and fixed into the flange niche. Mounting can be carried out "on site", directly onto the installed door frame.		034973E0M2U	
Assembly type 4 for surface mounting with using housing 	SLIM-HELPPUSH push-button panel type 4 for mounting placed on surface using housing. With extra-strong protective housing, made in anodized silver finish aluminium (35 x 25 x 215 mm). Self-adhesive cover in polycarbonate, provided separately and designed to be used as final cover to hide the 4 fixing screws of the housing on the door frame. Useful when you wish to avoid recess-mounting or cuts on the door frame		034974E0M2U	
Assembly type 5 for recessed wall-mounting with flange and wall-mounting receptacle 	SLIM-HELPPUSH push-button panel type 5 with "mushroom" pressure button for recessed assembly using flange and wall box. Supplied with front flange in anodized aluminium with "silver" finish - 250x50 mm, thickness 4 mm, to be fixed to the housing by placing on wall surface. Self-adhesive cover in polycarbonate pre-assembled and fixed into the flange niche. Also fitted with wall box with "wings" for rapid anchoring (65 x 30 x 230 mm), in plastic taken from single block to be assembled "in a niche" in the wall to house the body of the push button panel. Wall niche and cable channel to be prepared beforehand.		034975E0M2U	

Special configurations available at extra charge: Cover with your logo and/or customized.

For sizes, measurements and details of chasing, application examples and connection diagrams, see page 73.

SLIM-HELPPUSH PUSH-BUTTON PANELS - sizes, application examples and connection diagram

Assembly type 1 total alignment, lock recessed into surface without flange

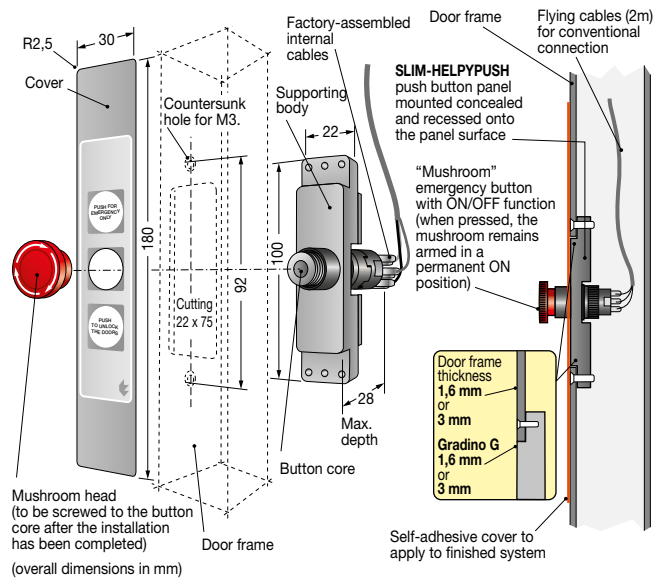

Assembly type 2 alignment at bottom with front flange "flush with surface" at bottom

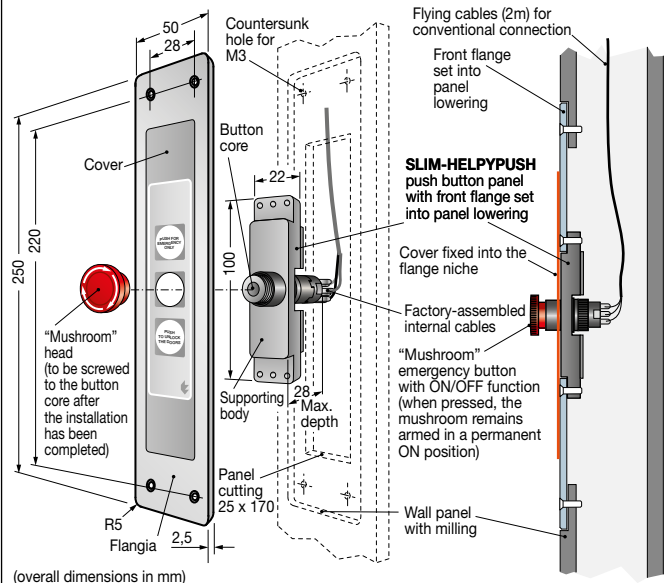

Assembly type 3 traditional fitting with front flange over the lock

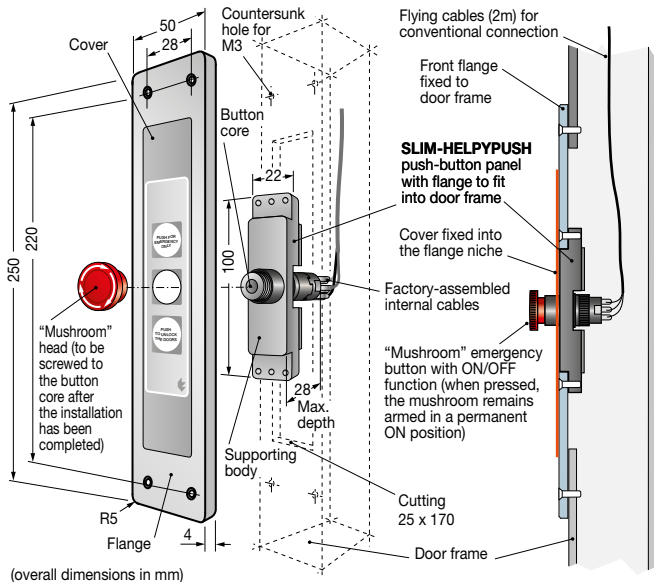

Assembly type 4 for mounting placed on surface using housing

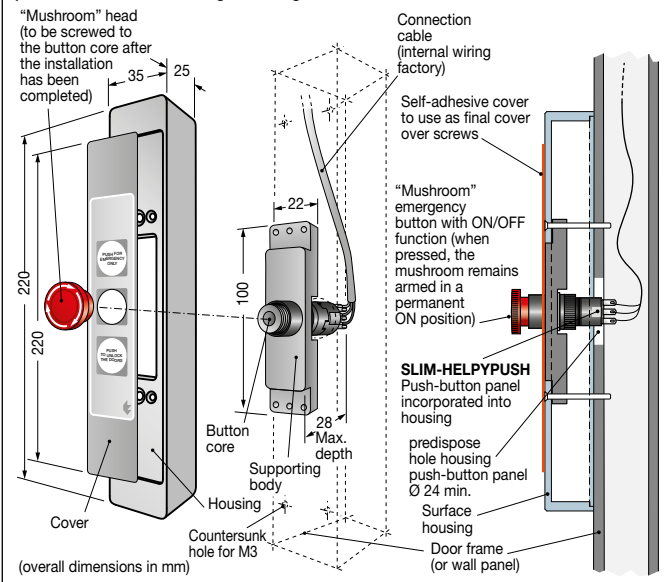

Assembly type 5 for recessed wall mounting with flange and wall box

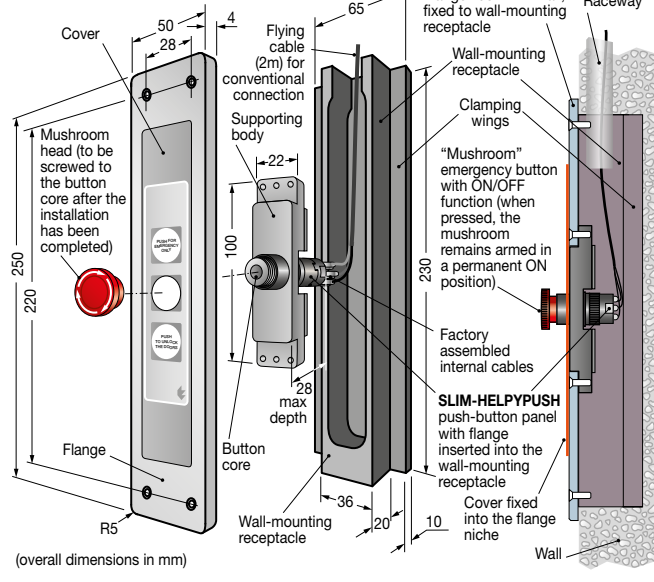

MUSHROOM BUTTON FUNCTIONING

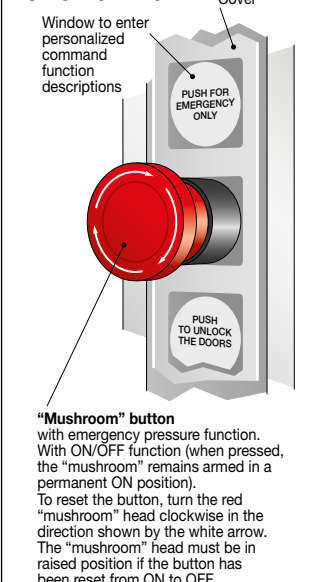

CONNECTION DIAGRAM valid for all 5 types

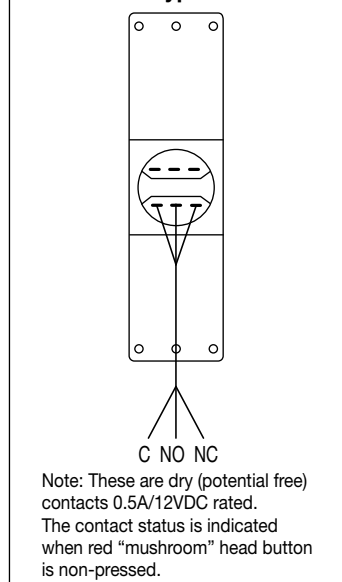

DOOR MANAGEMENT SYSTEMS