

Solenoid drop bolts, electrical door strikes and electromagnets in "CLEAN COVER" case made by solid block of anodised aluminium.

with technology

flexicon

MULTIFUNCTIONAL
INPUTS/OUTPUTS

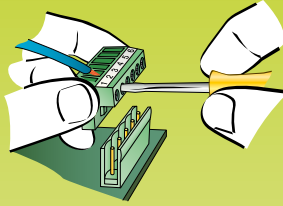

"FLEXICON" WIRING

Conventional cables systems with screw-type terminal board for medium and large section cables for medium and long range connections.

No cutting the frame
no work on internal frame grain!
Only a portable drill is needed to easily install **DRILL&GO** devices on any frame.

DRILL&GO
Cut-Free®

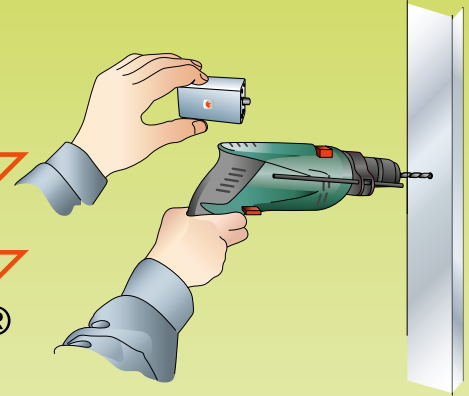

innovation

FOR EASY INSTALLATION
SURFACE MOUNT

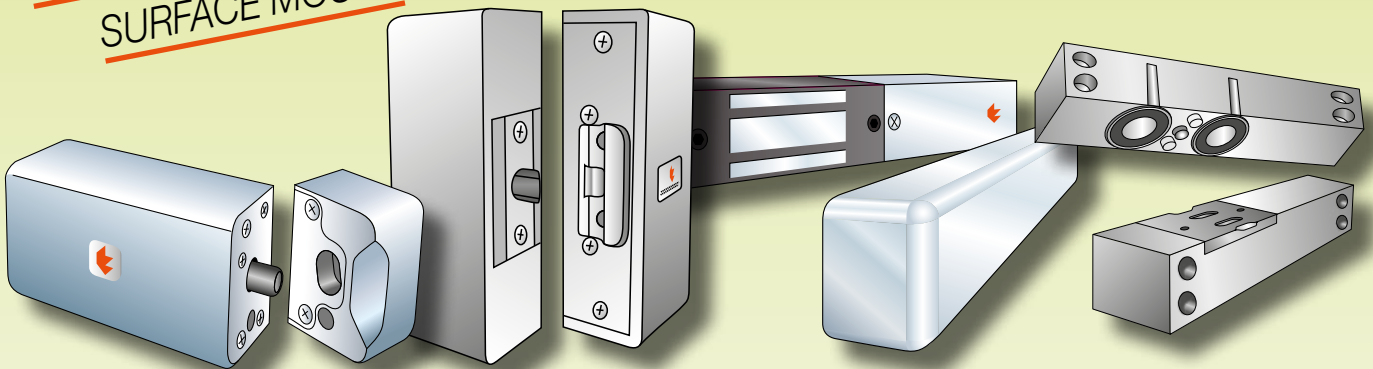

MICROREDLOCK
in "CLEAN COVER"
for surface-mounting

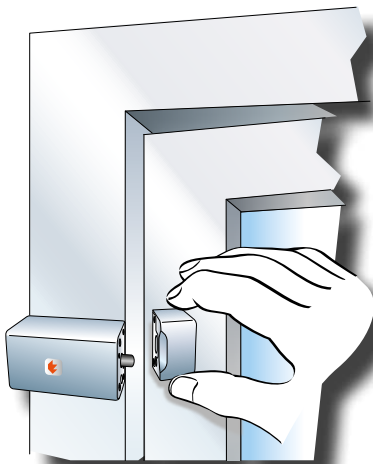

SLIM-DOORSTRIKE
in "CLEAN COVER"
for surface-mounting

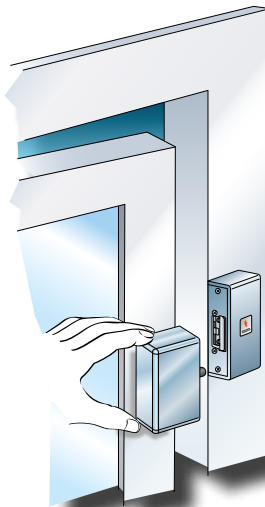

SLIM-MINISENTRYLOCK
and **SLIM-SHEARLOCK**
in "CLEAN COVER"
for surface-mounting

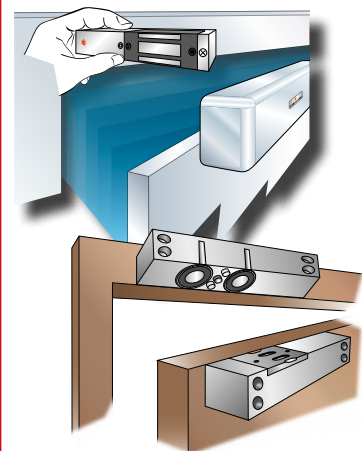

MICROREDLOCK, SLIM-DOORSTRIKE, SLIM-MINISENTRYLOCK and SLIM-SHEARLOCK

All provided with a "CLEAN COVER" made from silver-coloured, solid anodized aluminium, ultra-slim, designed to be easily installed on the door surface without any holes and/or cuts in the frame...

... it's **DRILL&GO CUT-FREE!**

INNOVATION

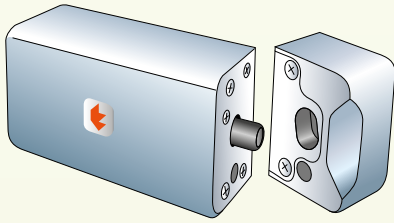

FOR SURFACE MOUNTING

innovation



MICROREDLOCK

in "CLEAN COVER" for surface mount

PROFESSIONAL TECNODIMENSIONE

ELECTRICAL DROP BOLTS

For easy surface mount with full coverage
"CLEAN COVER" made by solid block of anodised aluminium.

One unit... for 4 different needs.

- 1st** No frame cutting nor work on internal nervures.
Just drill to install = **DRILL&GO CUT-FREE**
- 2nd** Conventional wiring installation with screw-type terminal board = **FLEXICON**
- 3rd** Housed into CLEAN COVER fully made by a solid block of anodised aluminium, easy to clean with appropriate detergents = **CLEAN**
- 4th** Fail-safe; it automatically unlocks in the event of power failure freeing the door for emergency exit also in the event of fire = **FAIL-SAFE**

IDEAL FOR SURFACE APPLICATIONS ON "CLEAN ROOM" LOCKS.

1st
DRILL&GO
CUT-FREE



MICROREDLOCK
it is ultra-slim, designed to be easily installed on the door surface without any holes and/or cuts in the frame...
... it's **DRILL&GO CUT-FREE!**

2nd **flexi****con**
MULTIFUNCTIONAL INPUTS/OUTPUTS

Ideal for the installation on existing door frames in combination with conventional wiring systems and to be interfaced with any control unit such as PLC, microprocessor boards or conventional electronics.....
....it's **FLEXICON!**

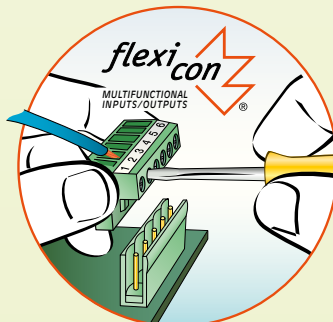

3rd **CLEAN**

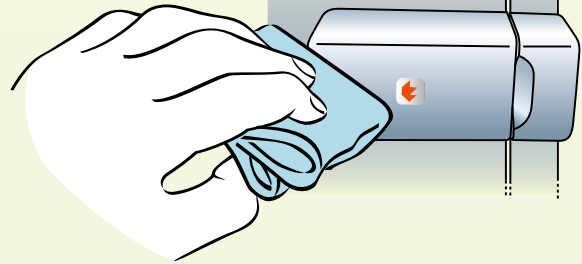

MICROREDLOCK
housed into protective smooth "CLEANCOVER" (roughness-free) ...
easy to clean with appropriate detergents...
... it's **CLEAN!**

4th
FAIL-SAFE



MICROREDLOCK
Automatic fail-safe unlock = bolt "in" without power, bolt "out" when powered. In the event of fire or power failure it automatically unlocks freeing the exit...
... it's **FAIL-SAFE!**

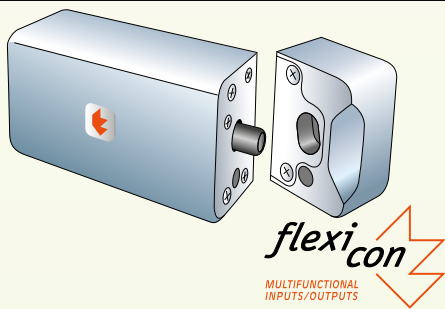

UNIVERSAL ELECTRICAL DROP BOLTS

MICROREDLOCK

in "CLEAN COVER"
for surface-mounting

Export Product-list
January 2024



TECNODIMENSIONE®

Mini-electrical drop bolt with full coverage "CLEAN COVER" made by solid block of anodised aluminium. Ideal for surface mount and surface applications on any type of "CLEAN ROOM" door frame.

Ordering information



Q.ty

MODELS

N°

MICROREDLOCK

for surface mounting in protective "CLEAN COVER" housing

Element "A" = housing with mini electrical drop bolt

3-lead flying cable (2 m) from door status Reed sensor

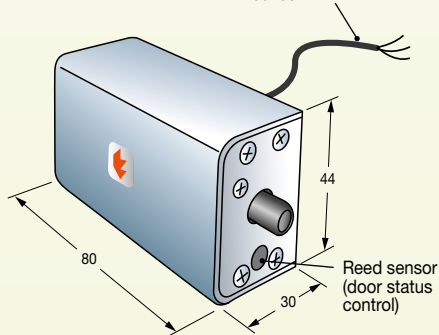

Element "B" = block counter (stricke)

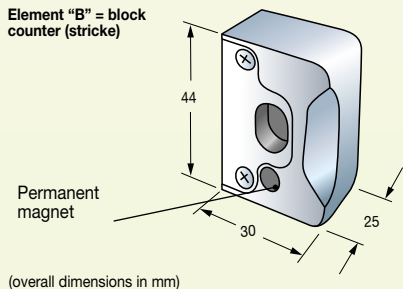

(overall dimensions in mm)

Ultra compact MICROREDLOCK mini-electrical drop bolt housed in protective "smooth" (roughness-free) and easy to clean case. Manageable and easy to install on door surfaces without any need to drill and/or cut door frames.

Models for 12 Vdc power supply

MICROREDLOCK "FLEXICON" electrical drop bolt in "CLEAN COVER" case complete with 1 flying 3-lead cable 2 m long (factory pre-cabled on unit), from the door status Reed sensor + 1 screw terminal board on electrical drop bolt for power connections. Protective Anticorodal, anodised and mechanically brushed aluminium "CLEAN COVER" made by solid block for easy installation with concealed retractable non-removable bracket.

The kit contains two components:

element "A": is the case that includes the electrical drop bolt to be secured on the door counter frame.

element "B": is the loose reference bolt to be secured on the door leaf frame matching element "A".

- FAIL-SAFE (anti-panic = unlock without power) version with 100% ED coil for a continuous operation.
- Includes a Reed sensor to control door status.
- Power supply 12 V DC/390 mA.
- Element A dimensions 80 x 30 x 44 mm
- Element B dimensions 25 x 30 x 44 mm
- Weight g 320

00803A2RCZM
Lh/Rh reversible

Models for 24Vdc power supply (on request)

Models with 24Vdc power supply (on request)
Mini-electrical drop bolt for MICROREDLOCK "FLEXICON" surface mount in "CLEAN COVER" like above but with 24Vdc/140mA power.

00803A4RCZM

MICROREDLOCK mini-electrical drop bolt in "CLEAN COVER" installation method

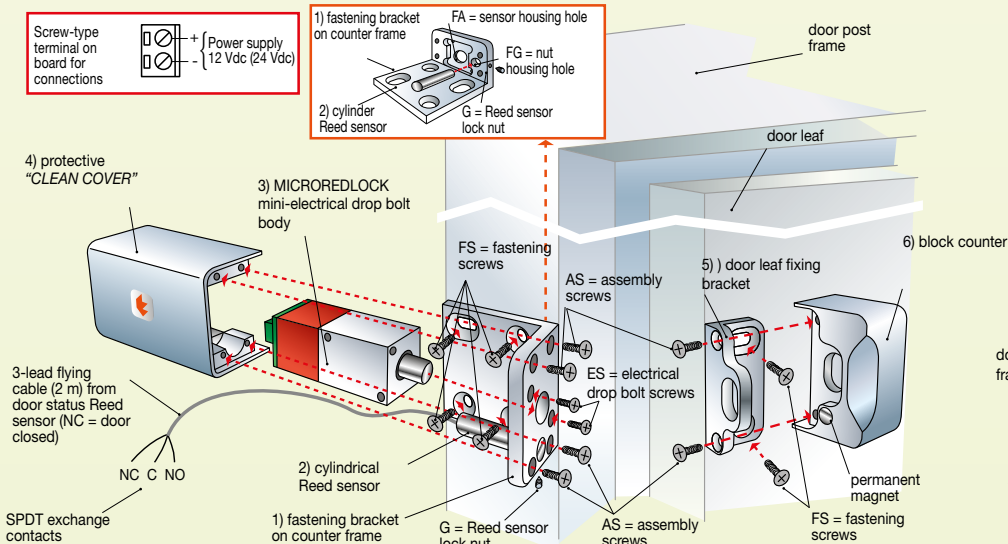

Example of a door complete with permanently assembled MICROREDLOCK mini-electrical drop bolt

element "A" (mini-electrical drop bolt) element "B" (block counter)

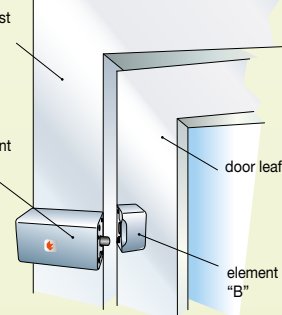
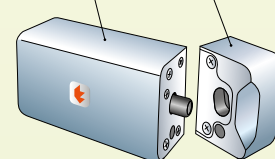

Note:

AS = 6 supplied assembly screws
ES = 2 supplied electrical drop bolt screws.

FS = 6 fastening screws supplied by the installer (based on the type of door frame).

G = 1 supplied nut.

Element "A" exploded view

"CLEAN COVER" that includes the mini-electrical drop bolt (to be secured on the counter frame)

Element "A" assembly sequence
to be secured on counter frame:

- secure the bracket (1) on the counter frame with the four FS fastening screws.
- place the cylindrical Reed sensor (2) in the matching FA hole.
- lock the sensor by screwing the G nut into the FG hole.
- secure the mini-electrical drop bolt body (3) to the bracket (1) with the two supplied ES screws.
- insert the protective cover (4) over the assembled electrical drop bolt (3), + bracket (1) + sensor (2). Complete by securing the case (4) with the four supplied AS assembly screws that bind the components.

Element "B" exploded view

"CLEAN COVER" that includes the block counter bolt (to be secured on the door leaf)

Element "B" assembly sequence
to be fastened on the door leaf

- secure the bracket (5) on the door leaf with the two FS fastening screws.
- insert the block counter bolt (6) on the bracket and fasten together with the two supplied AS assembly screws that bind the two components together.

INNOVATION

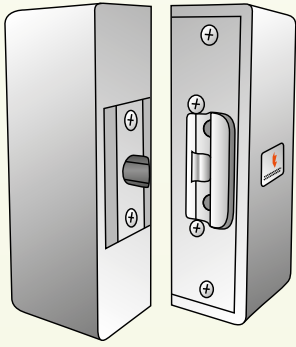

FOR SURFACE MOUNTING

innovation

SLIM-DOORSTRIKE
 in "CLEAN COVER" for surface mount
PROFESSIONAL TECNODIMENSIONE
ULTRA COMPACT ELECTRICAL DOOR STRIKE

For easy surface mount with full coverage "CLEAN COVER" made by single block of anodised aluminium.

One unit...
 for **4** different needs.

- 1st** No frame cutting nor work on internal nervures. Just drill to install = **DRILL&GO CUT-FREE**
- 2nd** Conventional wiring installation with screw-type terminal board = **FLEXICON**
- 3rd** Housed into CLEAN COVER fully made by single block of anodised aluminium, easy to clean with appropriate detergents = **CLEAN**
- 4th** Fail-safe; it automatically unlocks in the event of power failure freeing the door for emergency exit also in the event of fire = **FAIL-SAFE**

IDEAL FOR SURFACE APPLICATIONS ON "CLEAN ROOM" LOCKS.

1st DRILL&GO CUT-FREE



SLIM-DOORSTRIKE

it is ultra slim, designed to be easily installed on the door surface without any holes and/or cuts in the frame...

...it's **DRILL&GO CUT-FREE!**



Ideal for the installation on existing door frames in combination with conventional wiring systems and to be interfaced with any control unit such as PLC, microprocessor boards or conventional electronics.....

....it's **FLEXICON!**

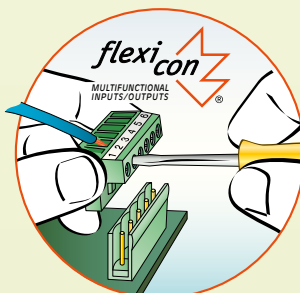

3rd CLEAN

SLIM-DOORSTRIKE housed into protective smooth "CLEAN COVER" (roughness-free) ... easy to clean with appropriate detergents...
 ... it's **CLEAN!**



4th FAIL-SAFE



SLIM-DOORSTRIKE

Automatic fail-safe unlock. In the event of fire or power failure it automatically unlocks freeing the exit...

... it's **FAIL-SAFE!**

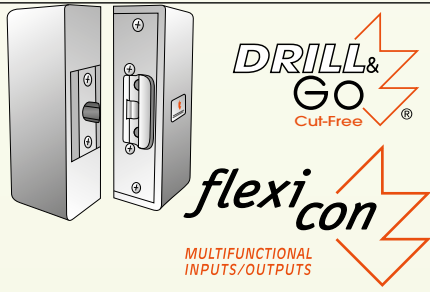

ULTRA COMPACT ELECTRICAL DOOR STRIKE

SLIM-DOORSTRIKE

in "CLEAN COVER"

by single block for surface mount

Export Product-list

January 2024



TECNODIMENSIONE

Electrical door strike with full coverage "CLEAN COVER" made by single block of anodised aluminium. Ideal for surface mount and surface applications on any type of "CLEAN ROOM" door frame.

Ordering information



Q.ty

MODELS

N°

SLIM-DOORSTRIKE
for surface mounting in protective "CLEAN COVER" housing

Element "A" = CLEANCOVER housing lock with mini spring bolt

Element "B" = CLEANCOVER housing with door strike

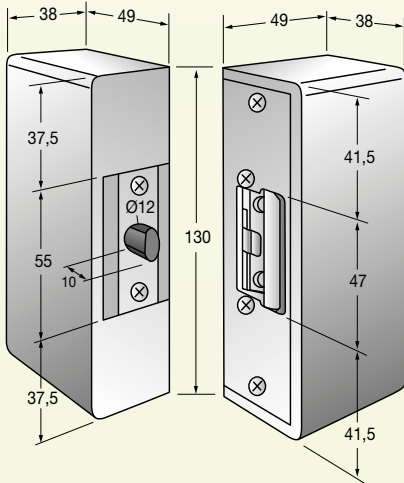

(overall dimensions in mm)

Ultra compact SLIM-DOORSTRIKE "FLEXICON" electrical door strike housed into protective "smooth" (roughness-free) and easy to clean case. Manageable and easy to install on door surfaces without any need to drill and/or cut door frames.

Models for 12 Vdc power supply

SLIM-DOORSTRIKE electrical door strike for conventional mount with "FLEXICON" technology and screw terminal board for conventional connection to any system, even pre-existent. SLIM-DOORSTRIKE "FLEXICON" electric door strike with screw-type terminal board, suitable for connections with any control unit such as PLC, microprocessor boards or conventional electronics. The kit contains two components:
element "A": is the case that includes the electrical reference to be secured on counter frame.
element "B": is the loose reference bolt to be secured on the door leaf frame matching element "A".

- FAIL-SAFE (anti-panic = unlock without power) version with 100% ED coil for a continuous operation.
- Includes a Reed sensor to control door status.
- Power supply 12 V DC/390 mA.
- Overall dimensions 137 x 49 x 38 mm (for each of the two units)
- Weight kg 1,100

0158J12DCM

Lh/Rh reversible kit for pull-open doors

0158J12SCM

Lh/Rh reversible kit for push-open doors

Models for 24Vdc power supply (on request)

Electrical door strike for surface mount SLIM-DOORSTRIKE "FLEXICON" in "CLEAN COVER" idem c.s. like above but with 24Vdc/140mA power.

0158J14DCM

0158J14SCM

SLIM-DOORSTRIKE "FLEXICON" ELECTRICAL BOLT IN "CLEAN COVER" ASSEMBLY METHOD

"A" element exploded view
Housing protective which includes mini spring bolt (to be mounted on door)

"B" element exploded view
Housing protective "CLEAN COVER" which includes electrical door strike (to be mounted on door-post)

Example of one door complete with doorstrike CLEANCOVER-DOORSTRIKE unit finally mounted

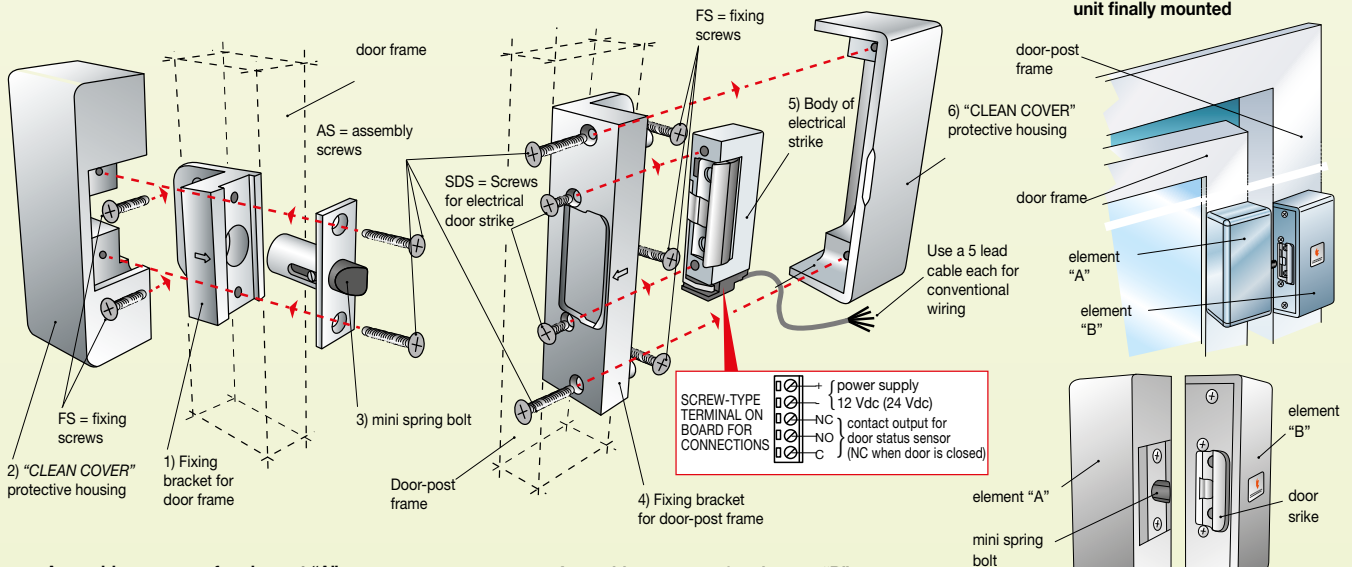

Assembly sequence for element "A"

to be mounted on door frame:

- secure the bracket (1) on the door with the two FS fixing screws
- Insert the protective housing (2) to cover the bracket (1).
- insert the mini spring bolt (3) in the hole in the bracket and assembly all parts with the two supplied pass-through AS screws that link all the three parts together.

Assembly sequence for element "B"

to be mounted on door-post frame:

- secure the bracket (4) on the door-post with three FS fastening screws.
- secure the electrical door strike body (5) with the two SDS screws supplied with the bracket (4).
- insert the protective housing (6) to cover the bracket (4) with electrical door strike (5) and connect all parts with the two AS supplied pass-through screws that link all the three parts together.

Note:
AS = 4 assembly screws
(+ SDS = 2 screws for electrical door strike) supplied together.

FS = 5 fixing and fastening screws on frame should be provided by installer (based on type of frame).



**PROFESSIONAL
ELECTRICAL LOCKS**

Introduction to the choice of Mini electromagnets multipurpose

The entire range of Tecnodimensione's professional electromagnets is designed and built to meet the most demanding “electromagnetic lockout” requirements.

The types of mini-electromagnets are intended for:



- Applications on structures designed keep specific doors closed. Not necessarily to provide extreme resistance to attempted break-in, but whose purpose is that of monitoring to prevent forced entry and to discourage misuse, diversions or damage to access doors. Doors through which unauthorised persons must not pass (e.g. emergency exits, classified areas such as sterile rooms, hospital wards with problematic patient areas, etc.). At the same time, these controlled doors can be opened and unlocked without jamming in the event of a hazard, fire, etc., becoming safe passageways or escape routes with automatic panic release in the event of a power failure.



- Very small, compact and elegantly designed. They achieve their goal of being “the electromagnetic locking block” with the lowest aesthetic impact on the door structure compared to conventional electromagnets available on the market.



- Two holding functions: front anchoring with “magnetic adhesion” or recessed with “shear locking”.



- Functional purposes: “Fail-Safe” automatic anti-panic and crush safe.



- Power supply: 12Vdc/7mA (very low consumption unit).



- External protection: with anodised monobloc aluminium “Clean Cover” protective housing machined from solid, for easy, non-removable surface mounting with no visible screws.

MINI ELECTROMAGNETS MULTIPURPOSE

DRILL & GO
CUT-FREE

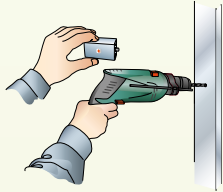

2 types available

**FOR EASY
SURFACE MOUNT
INSTALLATION**

Slim Minisentrylock Series in "CLEAN COVER" housing

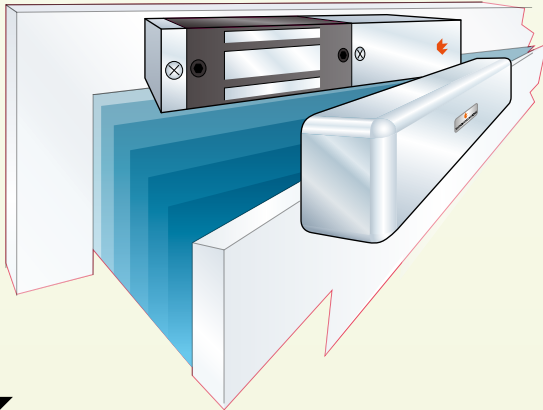

FRONT LOCKING

Front mounted mini-electromagnets with magnetic adhesion.

Frontal anchorage is achieved by magnetic adhesion between the face of the electromagnet and the face of the counter plate.

In practice, when the door is aligned in the stop moulding, the two coplanar surfaces fit together perfectly and a magnetic hold is established between them (with a powered holding electromagnet).

Key features:

- Fail-Safe: emergency unlock even in the event of a fault (release in the event of a power failure).
- Crush-safe: the unlock door command works even if pressure is applied to the door (e.g. crowds of people).
- Monitoring: fitted with a sensor to indicate door status (closed/open).

Slim Shearlock Series in "CLEAN COVER" housing

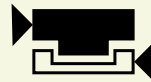
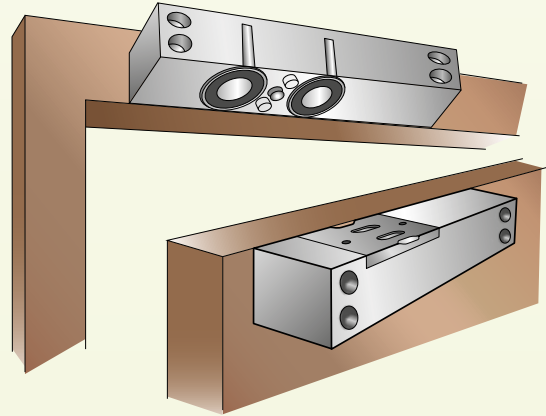

SHEAR LOCKING

Recessed shear-locking mini-electromagnets.

The shear anchoring is obtained by means of 2 stainless steel pins (located at the ends of the face of the electromagnet) which fit into the 2 correspondingly shaped seats (indentations) on the face of the floating counter plate.

In practice, when the door is aligned in the stop moulding, the electromagnet (when energised) attracts the face of the floating counter plate, which, when raised, aligns with the corresponding face of the electromagnet.

This causes the 2 stainless steel interlock with it. In this case, the high resistance shear locking is by recessed mounting.

Key features:

- Fail-Safe: emergency unlock even in the event of a fault (release in the event of a power failure).
- Resistance: is greatly increased (compared to simple magnetic adhesion) due to the magnetic interlocking of the two stainless steel pins.
- Monitoring: fitted with a sensor to indicate door status (closed/open)

with tecnologia

flexi con

MULTIFUNCTIONAL
INPUTS/OUTPUTS

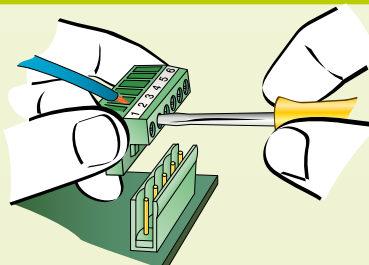

"FLEXICON" WIRING

Conventional cables systems with screw-type terminal board for medium and large section cables for medium and long range connections.

ELECTROMAGNET

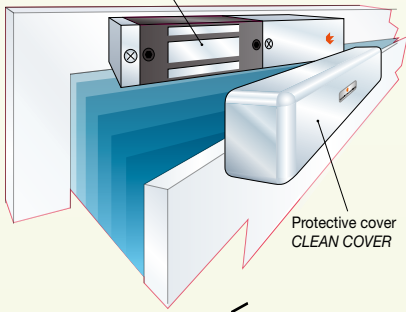

FOR SURFACE MOUNTING

innovation

SLIM-MINISENTRYLOCK in "CLEAN COVER"

TECNODIMENSIONE PROFESSIONAL ELECTROMAGNETS

Frontal door safety locks. Mini-compact unit with one-piece "CLEAN COVER" made of anodised aluminium.

One unit...
for **4** different needs.

- 1st** No frame cutting nor work on internal nervures. Just drill to install = **DRILL& GO CUT-FREE**
- 2nd** Conventional wiring installation with screw-type terminal board = **"FLEXICON"**
- 3rd** Housed into CLEAN COVER fully made by single block of anodised aluminium, easy to clean with appropriate detergents = **CLEAN**
- 4th** Fail-safe; it automatically unlocks in the event of power failure freeing the door for emergency exit also in the event of fire = **FAIL-SAFE**

IDEAL FOR SURFACE APPLICATIONS ON "CLEAN ROOM" LOCKS.



1st
DRILL&GO CUT-FREE

DRILL&GO CUT-FREE
Cut-Free®

SLIM-MINISENTRYLOCK it is ultra slim, designed to be easily installed on the door surface without any holes and/or cuts in the frame...
... it's **CUT-FREE!**

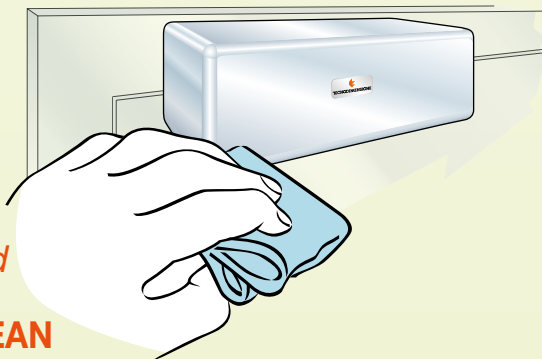

3rd
CLEAN

SLIM-MINISENTRYLOCK housed into protective smooth "CLEANCOVER" (roughness-free) ... easy to clean with appropriate detergents...
... it's **CLEAN!**

2nd *flexi*con
MULTIFUNCTIONAL INPUTS/OUTPUTS

Ideal for the installation on existing door frames in combination with conventional wiring systems and to be interfaced with any control unit such as PLC, microprocessor boards or conventional electronics.....

...it's **FLEXICON!**

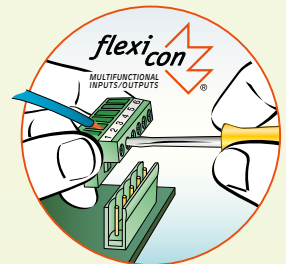

4th
FAIL-SAFE



SLIM-MINISENTRYLOCK Automatic fail-safe unlock. In the event of fire or power failure it automatically unlocks freeing the exit...
... it's **FAIL-SAFE!**

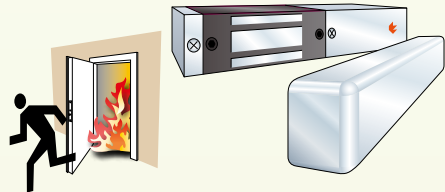

Automatic panic release and crash bar. In case of fire, when there is no power, it automatically releases, freeing the exit...it's FAIL-SAFE!

PROFESSIONAL MINI ELECTROMAGNETS SLIM-MINISENTRYLOCK in "CLEAN COVER"

Eletromagnetic crush-safe lock

Export Product-list
January 2024



TECNODIMENSIONE®

Mini electromagnet with full coverage "CLEAN COVER" made by single block of anodised aluminium. Ideal for surface mount and surface applications on any type of "CLEAN ROOM" door frame.

Ordering information



Q.ty

MODELS

N°

SLIM-MINISENTRYLOCK "FLEXICON"

for surface mounting in protective "CLEAN COVER" housing

Element "A" = body of electromagnet

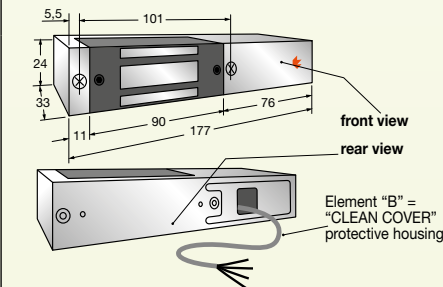

Element "B" = "CLEAN COVER" protective housing

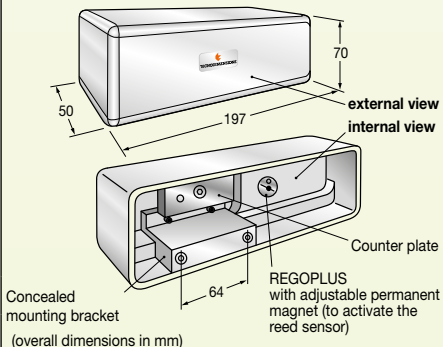

Ultra compact mini electromagnet SLIM-MINISENTRYLOCK "FLEXICON" encased in protective "smooth" (roughness-free) and easy to clean case. Manageable and easy to install on door surfaces without any need to drill and/or cut door frames.

Models for 12 Vdc power supply

SLIM-MINISENTRYLOCK "FLEXICON" mini electromagnet in "CLEAN COVER" case complete with 4-lead flying cable (2 m) of which 2 from the door status sensor and 2 for power. The unit can be interfaced with any control unit such as PLC, microprocessor boards or conventional electronics

The kit contains two components:

element "A": is the **electromagnet** (to be fitted to the top rail of the door frame) and

element "B": which is the **protective "CLEAN COVER"** (to be fitted over component "A" on the upper side of door leaf).

- 12 Vdc/70 mA power supply (units with very low consumption).
- Pressure resistance 60 Kp (equivalent to 600 Newton) to be enough and prevent adequately un-authorized opening of the door.
- Frontal lock with strike plate (armature)
- Adjustable Regoplus proximity reed sensor for controlling door status with 1A SPDT switch.
- Protective Anticorodal, anodised and mechanically brushed aluminium "CLEAN COVER" made by single block for easy installation with concealed non-removable bracket.
- Dimensions 197x70x50mm
- Weight Kg 1.55

0020804A2UM

Models for 24 Vdc power supply

SLIM-MINISENTRYLOCK "FLEXICON" electromagnet as above but for a 24 V DC /50 mA power supply

0020804A4UM

CROSS SECTION VIEW

Element "A" Electromagnet SLIM-MINISENTRYLOCK

Element "B" protective cover "CLEAN COVER"

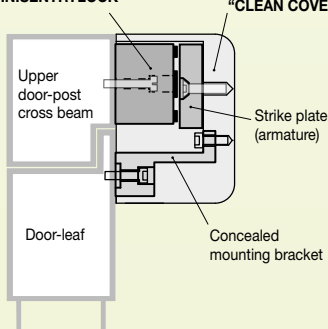

EXAMPLES OF WIREX FAST CONNECTING CABLES FOR "FLEXICON" MODELS

ELEMENT "A"

Rear view of electromagnet body with wirex cable fitted on

cable (2 m) for conventional wiring

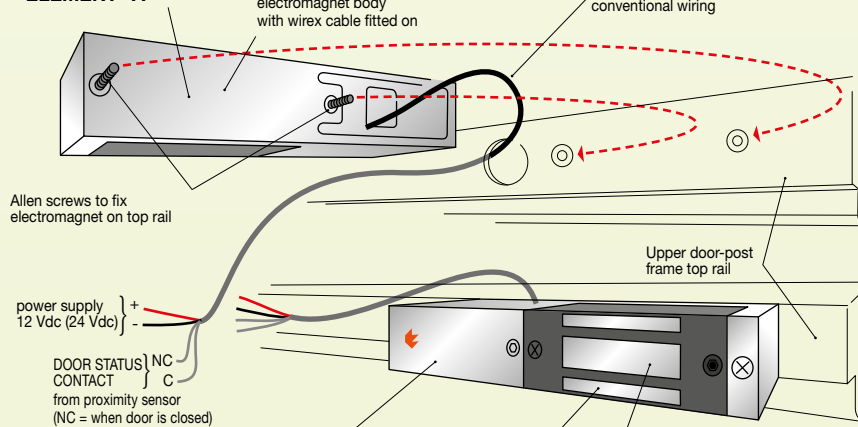

Allen screws to fix electromagnet on top rail

power supply
12 Vdc (24 Vdc)

DOOR STATUS } NC
CONTACT } C
from proximity sensor
(NC = when door is closed)

Rear compartment containing electronic circuits, internal factory terminal board (connections not to be removed) Reed sensor for door status control

Front view of electromagnet installed and wired

Electromagnet lock face.

ELEMENT "B"

Protective cover "CLEAN COVER" internal view

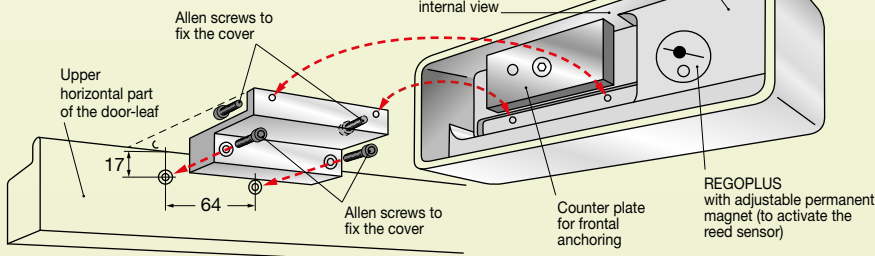

Allen screws to fix the cover

Upper horizontal part of the door-leaf

Allen screws to fix the cover

Counter plate for frontal anchoring

REGOPLUS with adjustable permanent magnet (to activate the reed sensor)

Door open

Element "A" Electromagnet SLIM-MINISENTRYLOCK

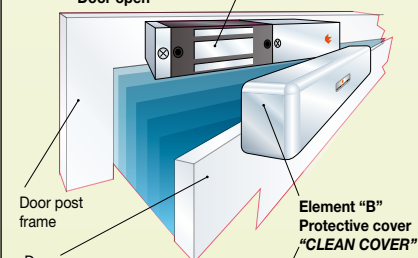

Door closed

Element "B" Protective cover "CLEAN COVER"



INNOVATION

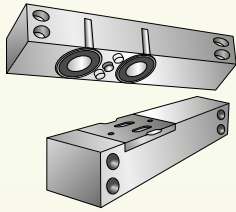

Automatic fail-safe unlock. In the event of fire or power failure it automatically unlocks freeing the exit....it's **FAIL-SAFE!**

PROFESSIONAL MINI ELECTROMAGNETS

SLIM-SHEARLOCK

in "CLEAN COVER" housing
Shear-locking electromagnet

Export Product-list

January 2024



TECNODIMENSIONE®

Mini elettromagnet with full coverage "CLEAN COVER" made by single block of anodised aluminium. Ideal for surface mount and surface applications on any type of door frame = DRILL&GO.

Ordering information



Q.ty

MODELS

N°

SLIM-SHEARLOCK

"DRILL&GO" shear-locking holding electromagnet for surface-mounting

Ultra compact mini electromagnet **SLIM-MINISENTRYLOCK** en cased in protective "smooth" (roughness-free) and easy to clean case. Manageable and easy to install on door surfaces without any need to drill and/or cut door frames = DRILL&GO.

Element "A"

body of electromagnet

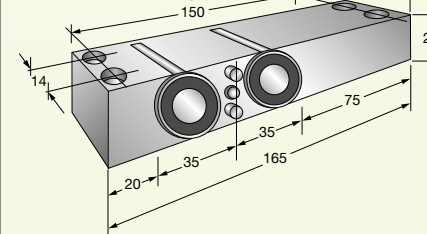

Element "A"

Body of electromagnet: rear view cable fitted

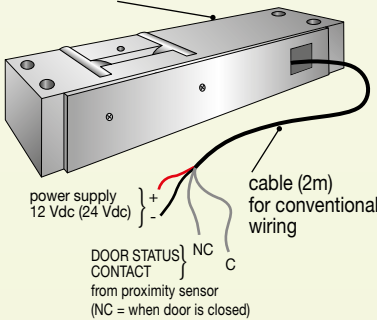

Models for 12 Vdc power supply

SLIM-SHEARLOCK fail-safe version (anti-panic) mini electromagnet in "CLEAN COVER" case complete with 4-lead flying cable (2 m) of which 2 from the door status sensor and 2 for power.

The kit contains two components:

element "A": is the electromagnet (to be fitted to the top rail of the door frame) and

element "B": which is the protective "CLEAN COVER" (to be fitted over component "A" on the upper side of door leaf).

- 12 Vdc/70 mA power supply (units with very low consumption).
- High thrust resistance due to 2 interlocking stainless steel pins
- Shear anchorage
- Protective Anticorodal, anodised and mechanically brushed aluminium "CLEAN COVER" made by single block for easy installation with concealed non-removable bracket.
- **element "A"**: overall dimensions electromagnet 165x29x29 mm
- **element "B"**: overall dimensions electromagnet 165x29x29 mm
- Weight kg 0,9

002093B2WEP

Models for 24 Vdc power supply

SLIM-SHEARLOCK electromagnet like above but with 24 Vdc/50 mA power supply

002093B4WEP

Element "B"

Floating locking anchor

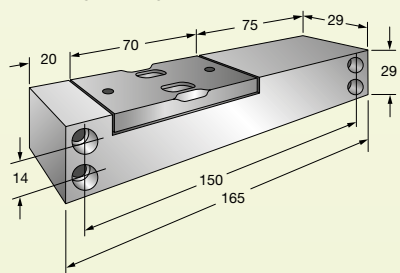

minimum distance 2 mm

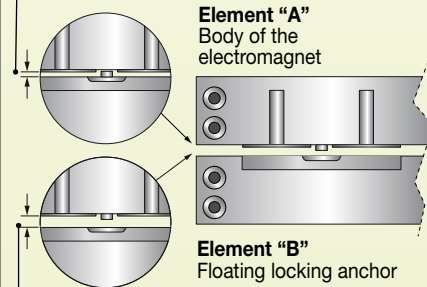

maximum distance 5 mm

(dimensions in mm)

EXAMPLES OF CONNECTING ELECTROMAGNET SLIM-SHEARLOCK

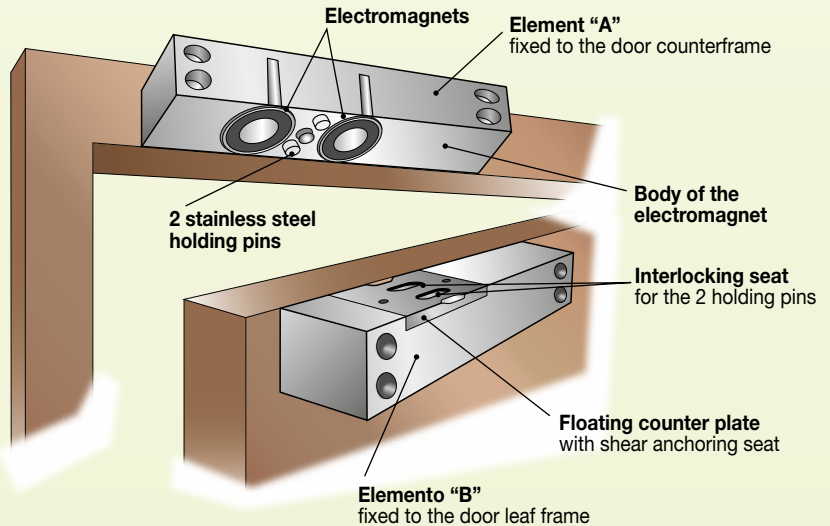

SLIM-SHEARLOCK ELECTROMAGNET anchored to the closing door

Holes for screws housing